



COMMERCIAL SPLIT CONDENSING UNIT

FORM NO. ATZ-207 REV. 1
Supersedes Form No. ATZ-207

TZAA- HIGH EFFICIENCY SERIES NOMINAL SIZES 7.5 TON [26.38 kW]



7.5 TON MODEL [26.38 kW]

This product is shipped with a nitrogen holding charge that must be vented prior to evacuation and charging and is identified by a tag on the unit shipping carton and on one of the unit service valves.

This product is only intended for Commercial Condensing Unit change-out in existing R-22 systems with a matched indoor unit.

This product must be charged with R-22 refrigerant meeting AHRI 700 purity standard.



TABLE OF CONTENTS



Unit Features & Benefits	3
Model Number Designation	4
Selection Procedure	5
Unit Dimensions	6
Performance Data	7
Electrical Data	8
Cooling Performance Data	9
Typical Installation	10-11
Accessories	12
Wiring Schematic	13
Sequence of Operation	14
Sample Specifications	14
Limited Warranty	16

These quality features are included in the Thermal Zone® Package Air Conditioner



STANDARD FEATURES INCLUDE:

- **CABINET**—Galvanized steel with powder coat paint finish. The powder coat paint finish is high gloss, durable and capable of withstanding a 1000-HR salt spray test per ASTM B117. The unit is of the frame and panel type of construction which allows all access panels to be opened or removed without affecting the structural strength of the unit. Fastening screws are also of the 1000-HR type. Stamped louver panels offer 100% protection for the condenser coil.
- **BASE PAN**—Galvanized steel with powder coat paint finish.
- **SERVICE ACCESS**—Control box with separation between line and control voltages, as well as compressor and other refrigerant controls are accessible through removable panel without affecting normal operation of unit.
- **FAN MOTOR**—Condenser fan motor(s) are mounted on removable top panel(s) which bring the motor(s) out to you and expose entire condenser coil for cleaning.
- **COMPRESSOR**—The Scroll Compressor is hermetically sealed with internal high temperature protection, and durable insulation on motor windings. The entire compressor is mounted on rubber grommets to reduce vibration and noise. Compressors have an internal pressure relief assembly to protect against excessive pressure differential. There is a separate compressor compartment for easy service access.
- **COMPRESSOR CRANKCASE HEATER**—External wrap-around heater helps prevent refrigerant migration to the compressor oil during long off periods.
- **CONDENSER COILS**—Constructed with copper tubes and aluminum fins mechanically bonded to tubes for maximum heat transfer capabilities. All coil assemblies are leak tested up to 450 PSIG internal pressure.
- **REFRIGERANT CONNECTIONS**—All field sweat joints are made external of the unit and are located close to the ground for a neat looking installation.
- **LOW AMBIENT CONTROL**—A pressure sensitive fan cycling control allows operation of units down to 0°F [-18°C].
- **HIGH PRESSURE CONTROL**—Manual reset control deactivates system if abnormally high pressure occurs.
- **LOW PRESSURE CONTROL**—Automatic reset control deactivates system if abnormally low pressure or refrigerant loss occurs.
- **SERVICE VALVES**—Standard on liquid and suction lines.
- **CONDENSER FAN MOTORS**—Direct drive, single-phase permanently lubricated “PSC” motors with inherent overload protection.
- **TRANSFORMER**—50VA step-down type, from Line to 24 volts.
- **CONTACTOR**—The contactor is an electrical switch which operates the compressor and condenser fans. Its 24 volt coil is activated through the High Pressure Control and Low Pressure Control on a call for cooling.
- **EQUIPMENT GROUND**—Lug for field connection of ground wire.
- **TESTING**—All units are run tested at the factory prior to shipment. Units are shipped with a holding charge of nitrogen.
- **CONTROL BOX**—The control box is located in the top corner of the cabinet providing for easy access through a service panel.
- **COMPRESSOR TIME DELAY CONTROL**—Compressor will remain off for five minutes after power or thermostat interruption, allowing system pressures to equalize. (Model No. RXMD-B01)
- **FILTER/DRIER**—A liquid line filter drier is shipped with each unit for field installation.

[] Designates Metric Conversions

MODEL IDENTIFICATION—TZAA- SERIES



TZ A A - 090 C A 757

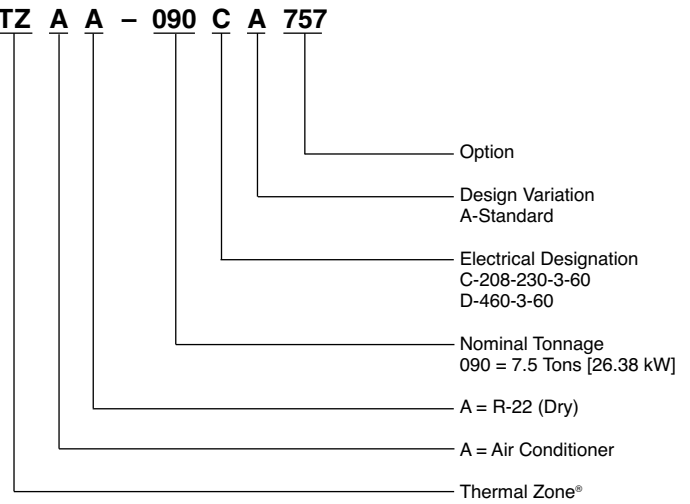

[] Designates Metric Conversions

SELECTION PROCEDURE— MATCHED SYSTEMS

Example 1: Determine the Net System Performance of Condensing Unit TZAA-090 with TZHGG-090 at 3360 CFM [1586 L/s] @ .30" [.07 kPa] external static pressure, 80°F [27°C] DB/67°F [19°C] WB entering indoor air and 95°F [35°C] DB outdoor ambient.

From Performance Data—Condensing Unit TZAA-090 with Air Handler TZHGG-090Z:

$$\text{Total Cap. (gross)} = 91.5 \times 1000 = 91,500 \text{ BTUH [26.82 kW]}$$

$$\text{Sens. Cap. (gross)} = 75.4 \times 1000 = 75,400 \text{ BTUH [22.09 kW]}$$

$$\text{Power (gross)} = 7.1 \times 1000 = 7,100 \text{ WATTS}$$

From Commercial Air Handler, Wet Coil Airflow Performance Data:

$$\text{Power} = 1,056 \text{ WATTS}$$

$$= 1,056 \times 3.412 = 3,603 \text{ BTUH [1.06 kW]}$$

Therefore, the Net Performance is:

$$\text{Total Cap. (Net)} = 91,500 - 3,603 = 87,897 \text{ BTUH [25.76 kW]}$$

$$\text{Sens. Cap (Net)} = 75,400 - 3,603 = 71,797 \text{ BTUH [21.04 kW]}$$

$$\text{Power (Net)} = 7,100 + 1,056 = 8,156 \text{ WATTS}$$

$$\text{EER} = 87,897 \div 8,156 = 10.78 \text{ BTUH [3.15 w/w] WATT}$$

Example 2: Determine the Sensible Net Capacity at 75°F [27°C] DB entering indoor air with the other conditions from Example 1 being the same.

From Performance Data—Condensing Unit TZAA-090 with Air Handler TZHGG-090

$$\text{Sens. Cap (Net)} = 71,797 \text{ BTUH [21.04 kW]}$$

(from Example 1)

Adjust Capacity for temperature other than 80°F [27°C] entering air:

$$\text{Adjustment: } [1.10 \times 3360 \times (1-.16) \times (75-80)] = - 15,523 \text{ BTUH [4.54 kW]}$$

Therefore, Sensible Capacity (Net) at 75°F [24°C] entering air is:

$$71,797 - 15,523 = 56,274 \text{ BTUH [16.49 kW] (Sens.)}$$

Example 3: Determine Net System Capacity Performance with 150 feet [45.7 m] equivalent length of 1³/₈" [34.9 mm] O.D. vapor line, with other conditions in example 1 being the same.

From piping chart, Vapor Line System Capacity Loss, in this booklet:

$$\text{Capacity Loss} = 1.3\% \text{ per } 100 [30.5\text{m}] \text{ feet of line}$$

The condensing unit Performance Data includes 25 feet [7.6 m] of recommended vapor line; therefore, calculate the System performance with 125 feet [38.1 m] of additional line:

$$\text{Total Cap. (gross)} = 91,500 - [(.013 \times 125 \div 100) \times 91,500] = 90,013 \text{ BTUH [26.38 kW]}$$

$$\text{Sens. Cap (gross)} = 75,400 - [(.013 \times 125 \div 100) \times 75,400] = 74,175 \text{ BTUH [21.73 kW]}$$

Thus, the Net Performance is:

$$\text{Total Cap. (Net)} = 90,013 - 3,603 = 86,410 \text{ BTUH [25.32 kW]}$$

$$\text{Sens. Cap. (Net)} = 74,175 - 3,603 = 70,572 \text{ BTUH [20.68 kW]}$$

[] Designates Metric Conversions

UNIT DIMENSIONS—TZAA- SERIES

UNIT DIMENSIONS & WEIGHTS

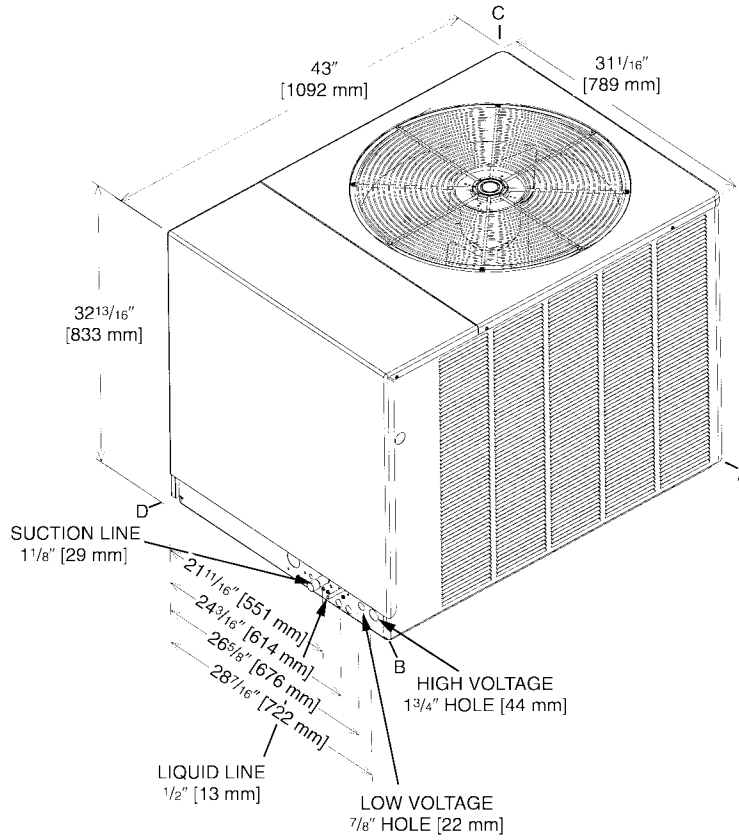

7.5 TON [26.38 kW]

CORNER WEIGHTS (LBS.) [kg]

MODEL	TOTAL WEIGHT LBS. [kg]	Corner Weights, Lbs. [kg]			
		A	B	C	D
TZAA-090	318 [144]	53 [24.0]	84 [38.1]	71 [32.2]	110 [49.9]

[] Designates Metric Conversions

PERFORMANCE DATA @ AHRI STANDARD CONDITIONS—COOLING: TZAA-

MODEL NUMBERS		80°F [26.5°C] DB/67°F [19.5°C] WB INDOOR AIR 95°F [35°C] DB OUTDOOR AIR				SOUND RATING dB	INDOOR CFM [L/s]
OUTDOOR UNIT TZAA-	INDOOR COIL AND/OR AIR HANDLER	TOTAL CAPACITY BTU/H [kW]	NET SENSIBLE BTU/H [kW]	NET LATENT BTU/H [kW]	EER		
090CA757	TZHGG-090CAZ	86,000 [25.2]	63,500 [18.6]	22,500 [6.6]	11.2	86	2,800 [1321]
090DA757	TZHGG-090DAZ	86,000 [25.2]	63,500 [18.6]	22,500 [6.6]	11.2	86	2,800 [1321]

① Highest sales volume tested combination required by D.O.E. test procedures.

[] Designates Metric Conversions

ELECTRICAL & PHYSICAL DATA: TZAA-

Model No. TZAA-	ELECTRICAL						PHYSICAL									
	Phase Frequency (Hz) Voltage (Volts)		Compressor		Full Load Amperes (FLA)		Minimum Circuit Ampacity Amperes		Fuse or HACR Circuit Breaker		Outdoor Coil			Refrig. Per Circuit Oz. [g]		Weight
			Rated Load Amperes (RLA)	Locked Rotor Amperes (LRA)	Fan Motor	Minimum Amperes	Maximum Amperes	Face Area Sq. Ft. [Sq. m]	No. Rows	CFM [L/s]			Net Lbs. [kg]	Ship Lbs. [kg]		
090CA757	3-60	208/230	22.4/22.4	164	2.2	31/31	50/50	23 [2.14]	2.0	4700 [2218]		213 [6038]	318 [144.2]	341 [154.7]		
090DA757	3-60	460	10.9	100	1.3	15	25	23 [2.14]	2.0	4700 [2218]		213 [6038]	318 [144.2]	341 [154.7]		

[] Designates Metric Conversions

SYSTEMS PERFORMANCE—TZAA- SERIES

COOLING PERFORMANCE DATA

CONDENSING UNIT **TZAA-090**

WITH COOLING COIL **TZHGG-090Z**

		ENTERING INDOOR AIR @ 80°F [26.7°C] dbE ①									
		71°F [21.7°C]			67°F [19.4°C]			63°F [17.2°C]			
		3360 [1586]	2800 [1322]	2240 [1057]	3360 [1586]	2800 [1322]	2240 [1057]	3360 [1586]	2800 [1322]	2240 [1057]	
		DR ①	0.07	0.11	0.15	0.07	0.11	0.15	0.07	0.11	0.15
OUTDOOR DRY BULB TEMPERATURE °F [°C]	75 [23.9]	Total BTUH [kW] Sens BTUH [kW] Power	103.8 [30.4] 65.3 [19.1] 6.0	100.2 [29.4] 56.1 [16.4] 5.9	96.5 [28.3] 47.5 [13.9] 5.8	97.8 [28.7] 76.9 [22.5] 5.8	94.4 [27.7] 66.9 [19.6] 5.7	91.0 [26.7] 57.6 [16.9] 5.6	90.4 [26.5] 83.2 [24.4] 5.7	87.3 [25.6] 73.0 [21.4] 5.6	84.1 [24.6] 63.3 [18.5] 5.5
	80 [26.7]	Total BTUH [kW] Sens BTUH [kW] Power	102.5 [30.0] 65.4 [19.2] 6.3	98.9 [29.0] 56.2 [16.5] 6.2	95.3 [27.9] 47.7 [14.0] 6.1	96.5 [28.3] 77.0 [22.6] 6.1	93.1 [27.3] 67.0 [19.6] 6.0	89.7 [26.3] 57.7 [16.9] 5.9	89.1 [26.1] 83.3 [24.4] 6.0	86.0 [25.2] 73.1 [21.4] 5.9	82.9 [24.3] 63.5 [18.6] 5.8
	85 [29.4]	Total BTUH [kW] Sens BTUH [kW] Power	101.0 [29.6] 65.2 [19.1] 6.6	97.5 [28.6] 56.1 [16.4] 6.5	93.9 [27.5] 47.6 [13.9] 6.4	95.0 [27.8] 76.8 [22.5] 6.4	91.7 [26.9] 66.9 [19.6] 6.3	88.3 [25.9] 57.6 [16.9] 6.2	87.6 [25.7] 83.1 [24.3] 6.3	84.5 [24.8] 72.9 [21.4] 6.2	81.5 [23.9] 63.4 [18.6] 6.1
	90 [32.2]	Total BTUH [kW] Sens BTUH [kW] Power	99.3 [29.1] 64.6 [18.9] 6.9	95.8 [28.1] 55.6 [16.3] 6.8	92.4 [27.1] 47.3 [13.9] 6.7	93.3 [27.3] 76.2 [22.3] 6.8	90.0 [26.4] 66.4 [19.5] 6.7	86.8 [25.4] 57.3 [16.8] 6.5	85.9 [25.2] 82.5 [24.2] 6.6	82.9 [24.3] 72.5 [21.2] 6.5	79.9 [23.4] 63.0 [18.5] 6.4
	95 [35]	Total BTUH [kW] Sens BTUH [kW] Power	97.5 [28.6] 64.0 [18.8] 7.3	94.1 [27.6] 55.1 [16.1] 7.2	90.6 [26.5] 46.8 [13.7] 7.1	91.5 [26.8] 75.4 [22.1] 7.1	88.3 [25.9] 65.8 [19.3] 7.0	85.1 [24.9] 56.8 [16.6] 6.9	84.1 [24.6] 81.9 [24.0] 7.0	81.1 [23.8] 71.9 [21.1] 6.8	78.2 [22.9] 62.6 [18.3] 6.7
	100 [37.8]	Total BTUH [kW] Sens BTUH [kW] Power	95.5 [28.0] 62.9 [18.4] 7.7	92.1 [27.0] 54.1 [15.9] 7.5	88.8 [26.0] 46.1 [13.5] 7.4	89.5 [26.2] 74.3 [21.8] 7.5	86.3 [25.3] 64.8 [19.0] 7.4	83.2 [24.4] 55.9 [16.4] 7.3	82.1 [24.1] 80.8 [23.7] 7.3	79.2 [23.2] 71.0 [20.8] 7.2	76.3 [22.4] 61.7 [18.1] 7.1
	105 [40.6]	Total BTUH [kW] Sens BTUH [kW] Power	93.3 [27.3] 61.4 [18.0] 8.1	90.0 [26.4] 52.9 [15.5] 7.9	86.8 [25.4] 45.1 [13.2] 7.8	87.3 [25.6] 73.0 [21.4] 7.9	84.2 [24.7] 63.7 [18.7] 7.8	81.2 [23.8] 55.0 [16.1] 7.6	79.9 [23.4] 79.5 [23.3] 7.7	77.1 [22.6] 69.9 [20.5] 7.6	74.3 [21.8] 60.8 [17.8] 7.5
	110 [43.3]	Total BTUH [kW] Sens BTUH [kW] Power	91.0 [26.7] 59.9 [17.6] 8.5	87.8 [25.7] 51.6 [15.1] 8.4	84.6 [24.8] 43.9 [12.9] 8.2	85.0 [24.9] 71.4 [20.9] 8.3	82.0 [24.0] 62.3 [18.3] 8.2	79.0 [23.1] 53.8 [15.8] 8.0	77.6 [22.7] 77.6 [22.7] 8.2	74.9 [21.9] 68.5 [20.1] 8.0	72.1 [21.1] 59.6 [17.5] 7.9
	115 [46.1]	Total BTUH [kW] Sens BTUH [kW] Power	88.5 [25.9] 58.1 [17.0] 8.9	85.4 [25.0] 50.0 [14.6] 8.8	82.3 [24.1] 42.5 [12.5] 8.6	82.5 [24.2] 69.5 [20.4] 8.8	79.6 [23.3] 60.7 [17.8] 8.6	76.7 [22.5] 52.4 [15.4] 8.5	75.1 [22.0] 75.1 [22.0] 8.6	72.4 [21.2] 66.8 [19.6] 8.5	69.8 [20.5] 58.2 [17.1] 8.3

DR —Depression ratio
dbE —Entering air dry bulb
wbE —Entering air wet bulb

Total —Total capacity x 1000 BTUH
Sens —Sensible capacity x 1000 BTUH
Power—KW input

NOTES:

- ① When the entering air dry bulb is other than 80°F [27°C], adjust the sensible capacity from the table by adding [1.10 x CFM x (1 - DR) x (dbE - 80)].
- ② Data includes 25 feet [7.62 m] of recommended suction/liquid lines.

[] Designates Metric Conversions

TYPICAL INSTALLATIONS—TZAA- SERIES

TYPICAL REFRIGERANT PIPING RECOMMENDATIONS

General Notes:

1. Vertical risers not to exceed 60 feet [18.29 m].
2. Locate the condensing unit and evaporator(s) as close together as possible to minimize piping runs.
3. Condensing units are shipped with a nitrogen holding charge. Evacuate condensing unit before charging with refrigerant.

EQUIVALENT LENGTH (FT.) [m] OF STRAIGHT TYPE "L" TUBING FOR NON-FERROUS VALVES AND FITTINGS (BRAZED)						
TUBE SIZE (IN.) [mm] O.D.	SOLENOID VALVE	ANGLE VALVE	SHORT RADIUS ELL	LONG RADIUS ELL	TEE LINE FLOW	TEE BRANCH FLOW
LIQUID LINE						
1/2 [12.7]	70 [21.3]	24 [7.3]	4.3 [1.4]	3.2 [1.0]	1.7 [0.5]	6.6 [2.0]
5/8 [15.9]	72 [22.0]	25 [7.6]	5.7 [1.7]	3.9 [1.2]	2.3 [0.7]	8.2 [2.5]
3/4 [19.1]	75 [22.9]	25 [7.6]	6.5 [2.0]	4.5 [1.4]	2.9 [0.9]	9.7 [3.0]
7/8 [22.2]	78 [23.8]	28 [8.5]	7.8 [2.4]	5.3 [1.6]	3.7 [1.1]	12.0 [3.7]
SUCTION LINE						
1 1/8 [28.6]	87 [26.5]	29 [8.8]	2.7 [0.8]	1.9 [0.6]	5.2 [1.6]	8.0 [2.4]
1 3/8 [34.9]	102 [31.1]	33 [10.1]	3.2 [1.0]	2.2 [0.7]	6.9 [2.1]	10.0 [3.1]
1 5/8 [41.3]	115 [35.1]	34 [10.4]	3.8 [1.2]	2.6 [0.8]	8.7 [2.7]	12.0 [3.7]
2 1/8 [54.0]	141 [43.0]	39 [11.9]	5.2 [1.6]	3.4 [1.0]	12.0 [3.7]	16.0 [4.9]

RECOMMENDED VAPOR AND LIQUID LINE SIZES FOR VARIOUS LENGTHS OF RUN		
LINEAR LENGTH (FT.) [m]	LIQUID LINE O.D. SIZES (IN.) [mm]	VAPOR LINE O.D. SIZES (IN.) [mm]
	092*	092
0-15 [0-4.57]	1/2 [12.7]	1 1/8 [28.58]
16-50 [4.88-15.24]	1/2 [12.7]	1 1/8 [28.58]
51-100 [15.54-30.48]	1/2 [12.7]	1 3/8 [34.93]
101-150 [30.78-45.72]	1/2 [12.7]	1 3/8 [34.93]

NOTE: Runs between condenser and evaporator not to exceed 150' [45.7 m] linear length.

*See note ④ under liquid line pressure drop chart. Use 5/8" [15.88 mm] liquid line with solenoid valve.

LIQUID LINE PRESSURE DROP PER 100 FEET [30.48 m] EQUIVALENT LENGTH (TYPE L COPPER TUBING)

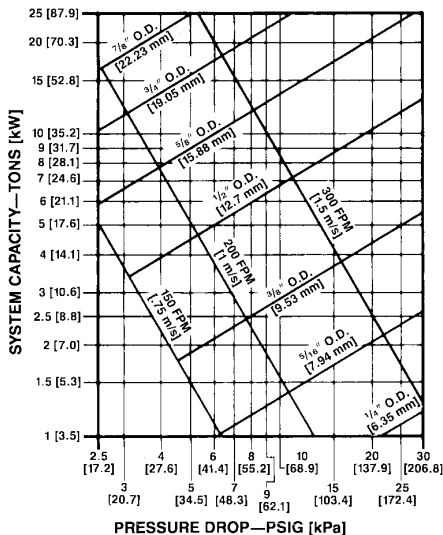

NOTES:

- 1) When evaporator coil is above condenser, the pressure drop due to vertical lift (.5 PSIG per foot of lift) [1.05 kPa per meter] **must** be added to the pressure drop derived from this curve.
- 2) Size liquid line for **no more** than 10°F [5.6°C] loss (approximately 50 PSIG [344.7 kPa] total pressure drop).
- 3) **Do not oversize liquid line.** Oversized liquid lines add significantly to the amount of refrigerant required to charge the system.
- 4) The maximum recommended velocity with solenoid valves or other quick closing devices in the liquid line is 300 FPM [1.5 m/s].

VAPOR LINE SYSTEM CAPACITY LOSS IN PERCENT PER 100 FEET [30.48 m] EQUIVALENT LENGTH (TYPE L COPPER TUBING)

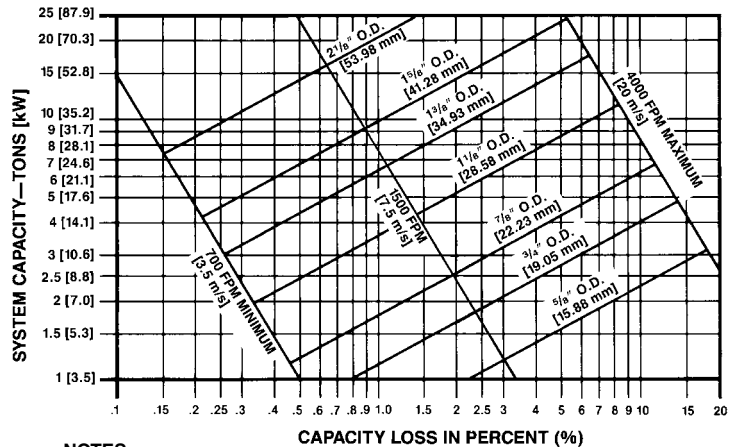

NOTES:

- 1) The minimum velocity line (700 fpm) [3.6 m/s] is recommended.
- 2) For vapor pressure drop (PSIG) [6.9 kPa], multiply percent (%) loss by 1.18.
- 3) Size vapor lines for no more than 2°F [1.1°C] loss which corresponds to approximately 3 PSIG [20.7 kPa] pressure drop.
- 4) Pitch all horizontal vapor lines downward in the direction of flow (1/2" [12.7 mm] to 10' [3.0 m] run).

WARNING

Do not use oxygen to purge lines or pressure system for leak test. Oxygen reacts violently with oil, which can cause an explosion resulting in severe personal injury or death.

[] Designates Metric Conversions

COIL ABOVE CONDENSING UNIT

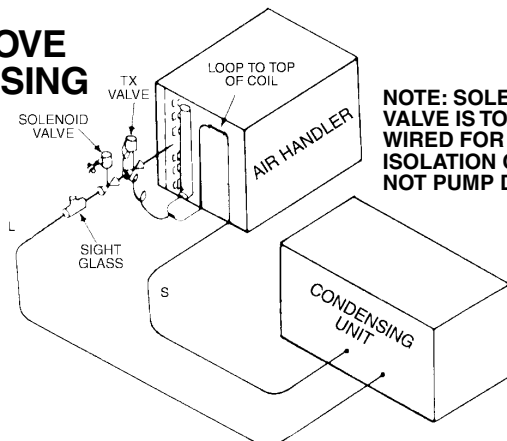

NOTE: SOLENOID VALVE IS TO BE WIRED FOR ISOLATION ONLY, NOT PUMP DOWN.

TYPICAL REFRIGERANT PIPING RECOMMENDATIONS (cont.)

REQUIRED OZS. R-410A CHARGE PER FT. [m] OF TUBING

TUBE SIZE O.D. (IN.) [mm]	LIQUID (OZ.) [g]	VAPOR (OZ.) [g]
1/2 [12.7]	1.20 [34.0]	—
5/8 [15.9]	1.86 [52.7]	—
7/8 [22.2]	2.67 [75.7]	.06 [1.7]
1 1/8 [28.6]	—	.15 [4.3]
1 3/8 [34.9]	—	.22 [6.2]
1 5/8 [41.3]	—	.29 [8.2]
2 1/8 [54.0]	—	.43 [12.2]

BASIC SYSTEM CHARGE*

UNIT MODEL	BASIC SYSTEM CHARGE, OZ, [g]*
TZAA-090	213 [6038]

*System with 0 feet [m] of tubing.

GENERAL INSTALLATION

The condensing unit should be installed outdoors. It should be located as near as possible to the evaporator section to keep connecting refrigerant tubing lengths to a minimum. The unit must be installed to allow a free air flow to the condenser coils.

If several units are installed adjacent to each other, care must be taken to avoid recirculation of air from one condenser to another. In all installations, adequate space must be provided for installation and servicing.

CLEARANCES

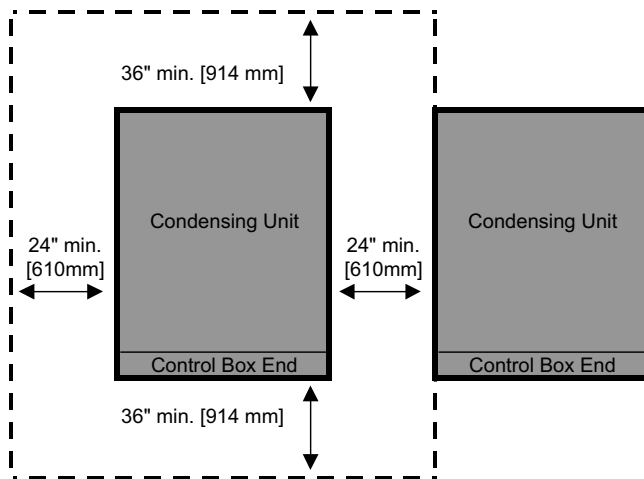

The unit must not be connected to any duct work. Do not locate unit under a roof drip; if necessary, install gutters, etc., to prevent water run-off from hitting the unit. To prevent air recirculation, it is recommended that the unit not be installed under an overhang, but if necessary **allow a minimum of 60 inches [1524 mm] above the unit for air discharge.**

ROOFTOP INSTALLATION

If rooftop installation is required, make certain that the building construction is adequate for the weight of the unit. (Refer to physical data chart.) Before placing the unit on the roof, make certain that the nylon rigging slings are of sufficient length to maintain equilibrium of the unit when lifting. Under no circumstances should the unit be lifted by only one corner for rooftop installation.

RIGGING

TZAA 090 MODEL

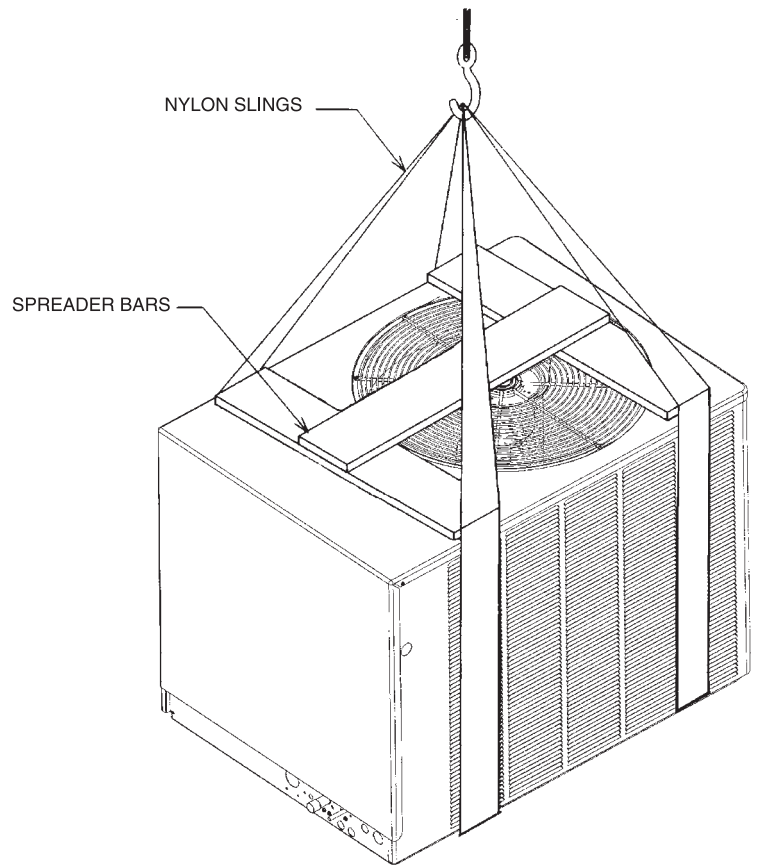

SLAB INSTALLATION

Condensing units should be set on a solid level foundation. When installed at ground level, the unit should be placed on a 6 inch [152.4 mm] cement slab. If the pad is formed at the installation site, do not pour the pad tight against the structure, otherwise vibration will be transmitted from the unit through the pad.

[] Designates Metric Conversions

ACCESSORIES—TZAA- SERIES

CONDENSING UNIT ACCESSORIES

ACCESSORY DESCRIPTION	MODEL NUMBER
Anti-Short Cycle Timer Kit	RXAT-A01
Sight Glass	RXAG-A048
Liquid Line Solenoid Valve*	RXAV-CD078

*May be used as isolation valve only. Do not use as a pump-down solenoid. Refer to system wiring diagram.

TYPICAL WIRING SCHEMATIC

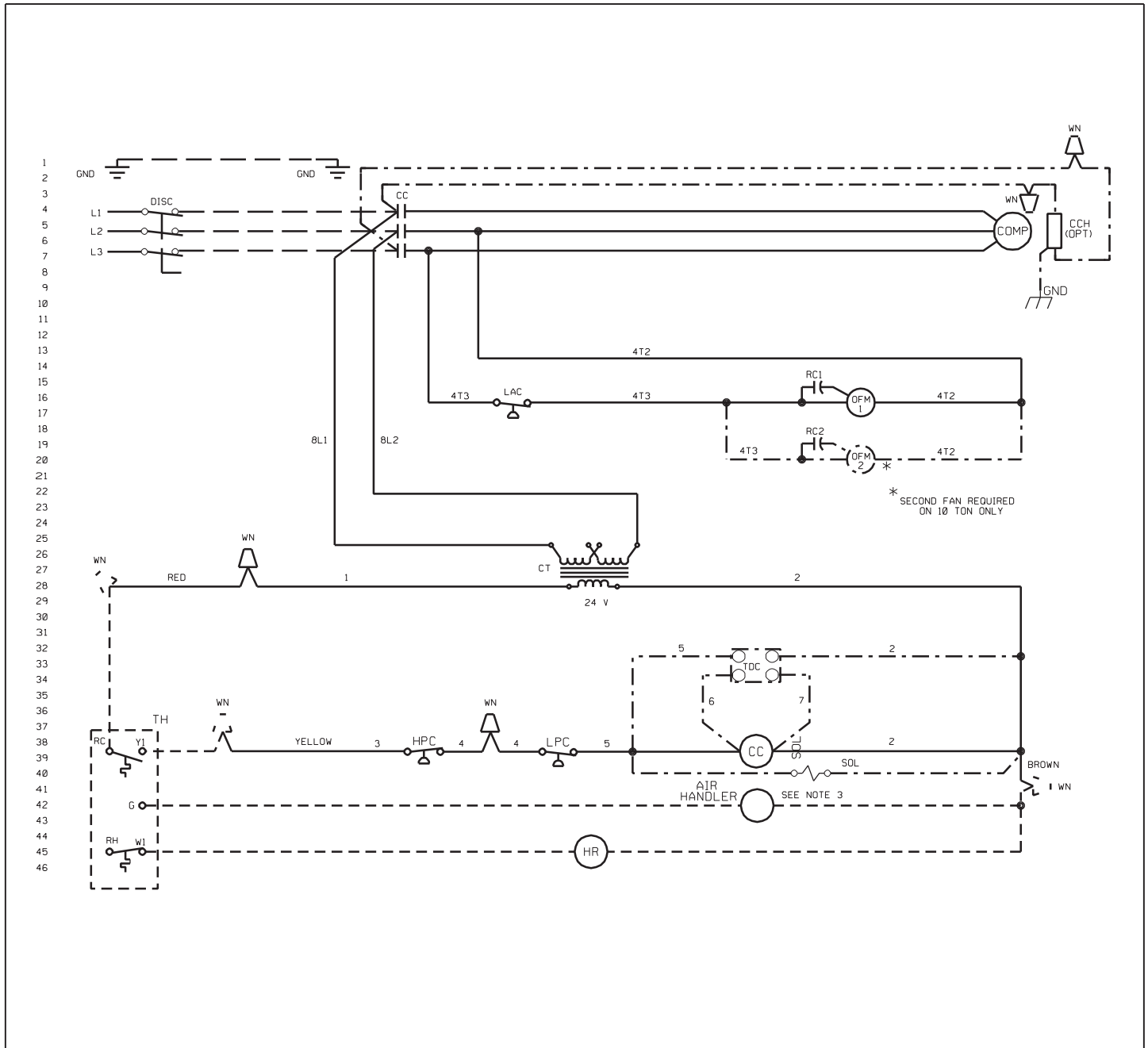

* SECOND FAN REQUIRED ON 10 TON ONLY

DWG. NO. 90-42456-02 REV. 14	COMPONENT CODE CC COMPRESSOR CONTACTOR CCH CRANKCASE HEATER COMP COMPRESSOR CT CONTROL TRANSFORMER HPC HIGH PRESSURE CONTROL HR HEATER RELAY LAC LOW AMBIENT CONTROL LPC LOW PRESSURE CONTROL OFM OUTDOOR FAN MOTOR RC RUN CAPACITOR TH THERMOSTAT (H/C) TDC TIME DELAY CONTROL WN WIRE NUT	NOTES: 1. REPLACEMENT WIRE & FUSES MUST BE SAME TYPE & SIZE AS ORIGINAL. 2. UNIT MUST BE PERMANENTLY GROUNDED & CONFORM TO N.E.C. & LOCAL CODES. 3. MAXIMUM IN RUSH VA NOT TO EXCEED 92 VA. 4. MINIMUM WIRE SIZE BASED ON 75 DEGREES C INSULATION COPPER WIRE.	WIRING INFORMATION LINE VOLTAGE -FACTORY STANDARD ————— -FACTORY OPTION - - - - - -FIELD INSTALLED - - - - - LOW VOLTAGE -FACTORY STANDARD ————— -FACTORY OPTION - - - - - -FIELD INSTALLED - - - - - REPLACEMENT WIRE -MUST BE THE SAME SIZE AND TYPE OF INSULATION AS ORIGINAL (105° C MIN.) WARNING -CABINET MUST BE PERMANENTLY GROUNDED AND CONFORM TO I.E.C., N.E.C., C.E.C., NATIONAL WIRING REGULATIONS, AND LOCAL CODES AS APPLICABLE.	WIRE COLOR CODE BK__BLACK O__ORANGE BR__BROWN PR__PURPLE BL__BLUE R__RED G__GREEN W__WHITE GY__GRAY Y__YELLOW	
	WIRING SCHEMATIC CONDENSING UNIT 6½, 7½, 10 TON & 12½ TON 208/230, 380, 460 3PH 60Hz & 200/220, 380/415 3PH 50Hz & 6½ & 7½ TON - 575 3PH 60Hz				
	DR. BY	APP. BY	DATE	DWG. NO.	REV
	MCB		8-29-90	90-42456-02	14

SEQUENCE OF OPERATION

1. When the room temperature is higher than the thermostat setting, the thermostat contacts close and energize the compressor contactor (CC) through the high pressure & low pressure control contacts. If the unit has “short cycled” and the optional time delay (TDC) has been supplied, the contactor coil (CC) will remain de-energized for up to five (5) minutes.
2. The system will continue cooling operation, as long as the contacts of all safety devices are closed and until the thermostat is satisfied.
3. When the thermostat is satisfied compressor or contactor (CC) is de-energized.

GUIDE SPECIFICATIONS

Furnish and install as shown on the drawing Thermal Zone® Model _____ air cooled condensing unit suitable for outdoor application.

COMPRESSOR—Unit shall have (1) compressor. It is to be of the welded hermetic type with durable insulation on the motor windings. It shall be externally mounted on rubber grommets to reduce vibration transmission and noise to surrounding area. Maximum power input shall not be more than _____ on 7.5 nominal ton [26.38 kW] units _____ at conditions specified.

LOW AMBIENT CONTROL—All units shall have standard head pressure controls that cycle the condenser fan motors to maintain condensing pressures for operation down to 0°F [°C] ambient.

CAPACITY—Capacity shall be _____ BTU/HR when operating at _____ °F [°C] saturated suction temperature.

MOTORS & FANS—Each unit shall have one (7.5 ton) [26.38 kW] sleeve bearing, permanently lubricated motor(s) fixed with direct-drive, multi-bladed fan(s). Motor(s) shall be equipped with inherent overload protection. Motor(s) & fan(s) shall be mounted on hinged top panel for easy access. Condenser air shall discharge vertically.

COILS—Coils shall be fabricated of 3/8" [9.53 mm] O.D. seamless copper tubing and aluminum fins with die-formed collars mechanically bonded to tubes arranged in a staggered pattern. All coils shall be submitted to an air pressure test of up to 300 PSIG after fabrication and dehydrated. Units shall be shipped with a dry nitrogen holding charge. Coil design shall permit removal of service panels without affecting operation of the

unit. Airflow shall be drawn through design providing uniform air distribution across the coil surface.

CASINGS—Casings shall make unit suitable for outdoor installation. Casing, base pan and framework shall be manufactured of galvanized sheet metal subjected to multistage cleaning, pre-treated and finished with a durable powder coat paint, capable of withstanding a 1000-HR salt spray test per ASTM B 117. Units shall have stamped louver panels offering 100% protection of the condenser coil face. Openings shall be provided for power. Dimensions of entire assembly shall be not more than _____ inches [mm] high, _____ inches [mm] long and _____ inches [mm] wide.

REFRIGERATION CIRCUIT—Shall include the compressor, the condenser coils, all internal refrigerant piping, a liquid line service valve. Refrigerant stubs shall be extended through the cabinet for external field connection without affecting accessibility to compressor compartment.

CONTROL PANEL—The panel shall be designed for single power source to the compressor and fan motor(s) and shall include low ambient fan cycling control, and compressor across-the-line contactor.

SAFETY CONTROLS—Manual reset high pressure and automatic reset low pressure control shall be provided.

FACTORY TESTING—All units shall be test run at the factory. They shall experience the following control testing procedures: high pressure control, switching of electrical components, and compressor operation.

[] Designates Metric Conversions

GENERAL TERMS OF LIMITED WARRANTY*

Thermal Zone® will furnish a replacement for any part of this product which fails in normal use and service within the applicable periods stated, in accordance with the terms of the limited warranty.

CompressorFive (5) Years
Any Other Part.....One (1) Year

***For Complete Details of the Limited Warranty, Including Applicable Terms and Conditions, See Your Local Installer or Contact the Manufacturer for a Copy.**

Before proceeding with installation, refer to installation instructions packaged with each model, as well as complying with all Federal, State, Provincial, and Local codes, regulations, and practices.

"In keeping with its policy of continuous progress and product improvement, the right is reserved to make changes without notice."